

# Total Oxidation Catalysis over Supported Metals

JAMES J. CARBERRY

Laboratory of Catalysis—Chemical Engineering Department, University of Notre Dame, Notre Dame, Indiana 46556

Received August 1, 1985

The role of metals in catalyzing the total oxidation of hydrocarbons and CO was discovered by H. Davy.<sup>1</sup> Open flames that illuminated early 19th century coal mines in Great Britain were rightly identified as a cause of a frightening number of explosions. Davy's inquiries led him to conclude that explosions were arrested when the open flame is surrounded by a gauze or screen composed of certain metals; presumably these hot screens or gauzes oxidized the combustible reactants before they reached the heretofore offending flame. Furthermore, he observed that the oxidizing activity of these metal gauzes was inhibited when carbonaceous matter and sulfur precursors were caused to be deposited upon the metal surface. Thus Davy discovered heterogeneous oxidation catalysis by metals, catalyst poisoning, and the catalytic gauze reactor.

In the wake of H. Davy's discoveries, his cousin E. Davy, Professor of Chemistry at Cork, Ireland, prepared a platinum catalyst in a high state of dispersion by imposing a Pt precursor upon porous supports (asbestos, sand). So dispersed in a finely divided state, the supported metal exhibited glowing oxidation activity at ambient temperature. Even "whisky" could be oxidized readily by E. Davy's supported Pt. Obviously Irish Whisky, as A. J. B. Robertson reports.<sup>1</sup> A cruel fate for so precious a reactant, some would aver.

Given the decades of research since Davy's findings one might be justified in assuming that metal-catalyzed total oxidation of hydrocarbons and surely the oxidation of CO are now rather well understood. Thus, when over 20 years ago we sought a "simple" reaction to demonstrate our spinning basket catalytic laboratory reactor concept,<sup>8</sup> we chose CO oxidation over supported Pt as well as Pd and Rh.<sup>9</sup> In the ensuing decades we have been taught how complex the "simple" can be.

Contemporary research in the wake of the early discoveries is devoted to the elucidation of the chemical mechanisms involved in metal surface catalyzed oxidation and establishing models of the chemical reactions, including decay phenomena, as bases for the design of large scale catalytic reactors.

The latter enterprise is the province of chemical reaction engineering, specific application to catalytic reactors having been set forth<sup>2</sup> and recent progress reviewed elsewhere.<sup>3</sup> No more need be said of this latter issue save to emphasize that these goals of understanding and application are ultimately interrelated insofar as the dream of a priori design of the catalytic reactor presupposes signal advances in the understanding of catalysis, per se. In turn the identification

of fundamental issues and their resolution are often inspired by the prevailing technology. Indeed Davy's empirical solution of a practical problem has launched nearly two centuries of synergistic effort in the science and application of heterogeneous catalysis. This Account is, appropriately, motivated by pollution abatement technology requirements, and the basic need to know.

## Oxidation Catalysis

The goal of understanding involves resolution of the questions of catalyzed reaction velocity for a given catalytic surface exposure. Further, what is the nature of catalyst mortality, i.e., activity decline? Finally, what is the chemical and physical nature of the catalyst surface? One seeks the answer these questions for a given reaction class in the light of Sir Hugh Taylor's insight set forth in 1925: The nature of the catalyst surface may likely depend upon the nature of the reaction catalyzed.<sup>4</sup>

The global rate of a solid-catalyzed reaction is expressed as moles of key reactant consumption per unit time per gram of total catalyst formulation (support, catalyst per se, and promoters). This rate is most conveniently measured directly by the employ of a gradientless reactor, i.e., one in which uniformity of concentrations and temperature is realized throughout the confines of the reactor, at constant feed and withdrawal rates. Pioneered by Hammett<sup>5</sup> in his kinetic studies of homogeneous reactions, the reactor (CSTR; continuously fed stirred tank reactor) consists of a well-baffled, highly agitated flask. The global rate is simply established by a material balance. Feed at flowrate  $Q$  and concentration  $C_0$  must, in steady state, equal effluent molar flow,  $QC$ , plus consumption of  $C$  by reaction in a reaction phase volume,  $V$

$$QC_0 = QC + VR$$

or rate

$$R = (C_0 - C)/\theta \quad (1)$$

where  $\theta$ , holding time, =  $V/Q$ .

Application of the CSTR concept to solid-catalyzed systems presented obvious difficulties with respect to disposition of the discrete catalyst particles or pellets. Remedies eventually emerged.<sup>6-11</sup> In Figure 1 are

(1) A. J. P. Robertson, "Catalysis of Gas Reactions by Metals", Logos Press Ltd., U.K., 1970.

(2) J. J. Carberry, "Chemical and Catalytic Reaction Engineering", McGraw-Hill, New York, 1976.

(3) J. J. Carberry, *Trans. Inst. Chem. Eng.*, **59**, 75 (1981).

(4) H. S. Taylor, *Proc. R. Soc. London, Ser. A*, **108**, 105 (1925).

(5) L. P. Hammett, *J. Am. Chem. Soc.*, **70**, 3444 (1948). See also K. G. Denbigh, *Trans. Faraday Soc.*, **40**, 352 (1944).

(6) I. Trotter, Ph.D. Thesis, Princeton University, 1962.

(7) F. E. Ford and D. Perlmutter, *Chem. Eng. Sci.*, **19**, 371 (1964).

James J. Carberry was born in Brooklyn, NY. Following service in World War II and an undergraduate degree at Notre Dame, he received his doctorate in Chemical Engineering at Yale. He joined the faculty at Notre Dame in 1961 after 6 years as an engineer with the Du Pont Co. He has been an NSF Senior Postdoctoral at Cambridge University, Senior Fulbright Scholar at University of Rome, and twice a Churchill Fellow at Cambridge and in 1976 received the R. H. Wilhelm Award in Chemical Reaction Engineering (AIChE).

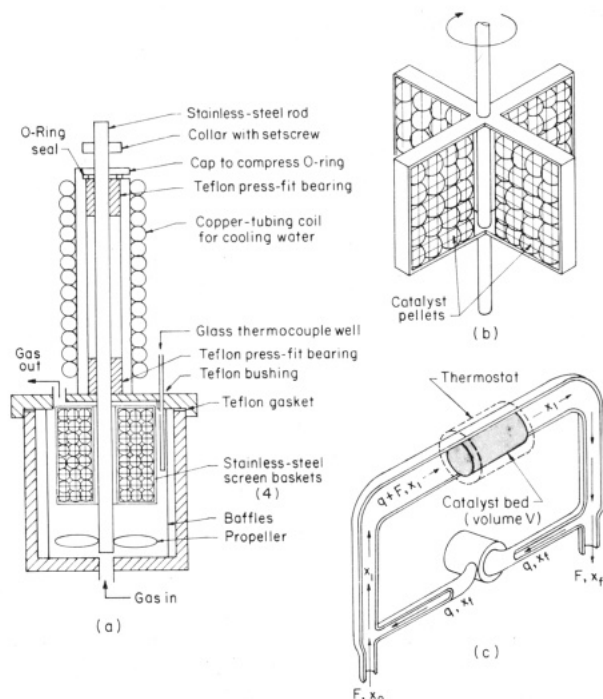

**Figure 1.** Gradientless catalytic reactors: (a) Notre Dame spinning basket; (b) basket; (c) open-loop recycle catalytic reactor.<sup>2</sup>

shown the Notre Dame spinning basket catalytic reactor and the fixed-bed recycle reactor. Both reactors are employed in our studies. Operated above 1400 rpm the spinning basket device is gradientless while at recycle to feed ratios greater than 25, the recycle reactor is gradientless. Weekman<sup>12</sup> has provided an exhaustive review of the diverse types of laboratory catalytic reactors.

### CO Oxidation Kinetics

Our early studies<sup>13</sup> were focused upon supported Pt-catalyzed oxidation of CO. This seemingly simple reaction proves to be complex indeed. The data, obtained by using the spinning basket (Figure 1a,b), teach that the rate-CO dependency (i.e., order in CO) varies from first to negative, and then zero order. The kinetic behavior is normal at low CO concentrations and abnormal at higher values of CO; behavior phenomenologically described by a rate expression of the form

$$R = k(\text{CO}) / (1 + K(\text{CO}))^2 \quad (2)$$

which form, if naively interpreted, suggests surface reaction between chemisorbed species as rate determining. No such inference can be prudently made: accord between a rate model (e.g., eq 2) and data does not justify unequivocal mechanistic conclusions.<sup>2</sup>

This early study<sup>13</sup> also revealed two other unanticipated features of this "simple" oxidation reaction. The specific rate, i.e., reaction velocity per exposed Pt area is a function of average crystallite size variation as in-

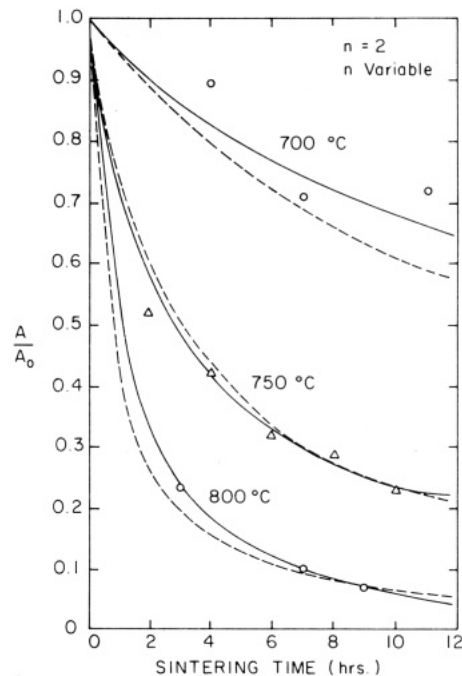

**Figure 2.** Area decline due to sintering in air of 0.05% Pt/Al<sub>2</sub>O<sub>3</sub>.<sup>13</sup>

duced by sintering. And oscillatory behavior is manifest.

The *specific* rate or turnover number, as Boudart taught, is a measure of the reaction's sensitivity to surface structure. It being known that surface morphology may vary with deposited metal crystallite size, then sensitivity or insensitivity of the reaction rate per surface atom or exposed surface area would be a measure of structure sensitivity (demanding reaction) or structure insensitivity (facile reaction). Thus if quite specific surface sites, of say Pt, are responsible for catalysis, their appearance or disappearance with changes in crystallite size would give rise to a variation of the velocity per surface atom (turnover number) with crystallite size variation. Should, on the other hand, the reaction be catalyzed by any type of exposed surface, the turnover number would be invariant with respect to crystallite size variations. The percent of deposited metal exposed is measured by chemisorption and/or titration.<sup>14,15</sup> Chemisorption and/or titration may be conducted by pulse-flow techniques, *provided* great care is exercised to prevent air leaks.<sup>16</sup>

Crystallite size variation can be achieved in catalyst preparation by variations in metal loading upon the support,<sup>17</sup> or crystallite growth may be sponsored by sintering—a process of crystallite growth in a high-temperature environment (Figure 2), about which more anon.

In the case of chemisorption/titration it is to be borne in mind that surface atom "counting" is not catalytic site counting, there being no reason to assert that all surface atoms are active catalytic sites. A case in point: Topsoe has recently shown that whereas the turnover number for NH<sub>3</sub> synthesis over promoted Fe varies with crystallite size changes, as measured by CO chemi-

(8) J. J. Carberry, *Ind. Eng. Chem.*, **56** (Nov.), 39 (1964).

(9) D. Tajbl, J. Simons, and J. J. Carberry, *Ind. Eng. Chem. Fundam.*, **5**, 171 (1966).

(10) J. Berty, *Chem. Eng. Prog.*, **70** (No. 5), 78 (1974).

(11) C. O. Bennett, M. B. Cutlip, and C. C. Yang, *Chem. Eng. Sci.*, **27**, 2255 (1972).

(12) V. W. Weekman, Jr., *AIChE J.*, **20**, 833 (1974).

(13) E. McCarthy, J. Zahradnik, G. C. Kuczynski, and J. J. Carberry, *J. Catal.*, **39**, 29 (1975).

(14) J. Benson and M. Boudart, *J. Catal.*, **4**, 704 (1965).

(15) Y. Nishiyama and H. Wise, *J. Catal.*, **32**, 50 (1974).

(16) L. Carballo, C. Serrano, J. J. Carberry, and E. Wolf, *J. Catal.*, **52**, 507 (1978).

(17) M. B. Palmer and M. A. Vannice, *J. Chem. Technol. Biotechnol.*, **30**, 205 (1980).

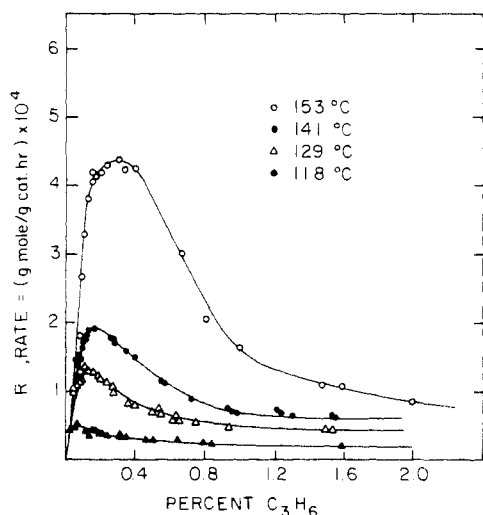

Figure 3. Global rate of Pt-catalyzed propylene oxidation vs. % propylene at diverse temperatures.

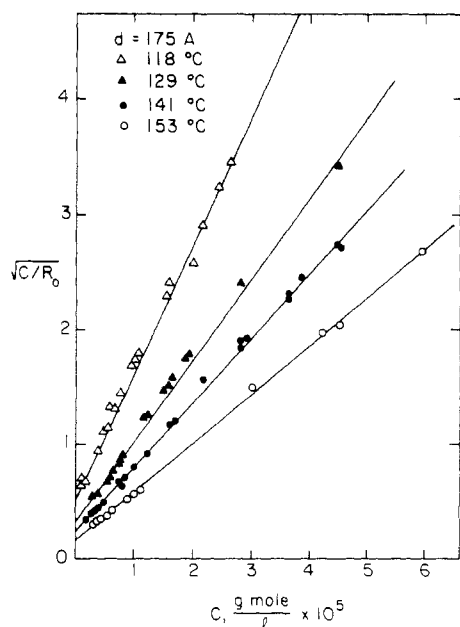

Figure 4. Organization of data of Figure 3 in accord with Langmuir-Hinshelwood model.

sorption, said turnover number is invariant with changes in crystallite size when  $N_2$  chemisorption is used as the atom counter.<sup>18</sup> So while surface Fe atoms of any nature chemisorb CO, only quite specific Fe atoms chemisorb  $N_2$ . As  $N_2$  chemisorption is generally believed to be the rate-determining step in  $NH_3$  synthesis, catalytic site counting with  $N_2$  is meaningful; surface atom counting with CO is misleading. Again H. S. Taylor's extraordinary insights of 1925 are validated.<sup>4</sup>

Inspired by Sir Hugh's warning we explored the effects of pretreatment upon kinetics. Utilizing the recycle reactor,<sup>19</sup> Figure 1c, CO oxidation kinetics were ascertained for (a) CO pretreated and (b)  $O_2$  pretreated commercial supported Pt. Pretreatment was conducted at 200 °C for several hours. In sum, we discovered that the rate of CO oxidation over supported Pt is twice as

(18) G. Haller, *Catal. Rev.—Sci. Eng.*, **23** (No. 4), 605 (1981).

(19) S. Paspek, J. J. Carberry, and A. Varma, *Chem. Eng. Educ.*, **14**, 78 (1980).

(20) J. J. Carberry, *Kinet. Katal.* **18**, 562 (1977). T. Huang and J. J. Carberry, submitted to *J. Catal.*

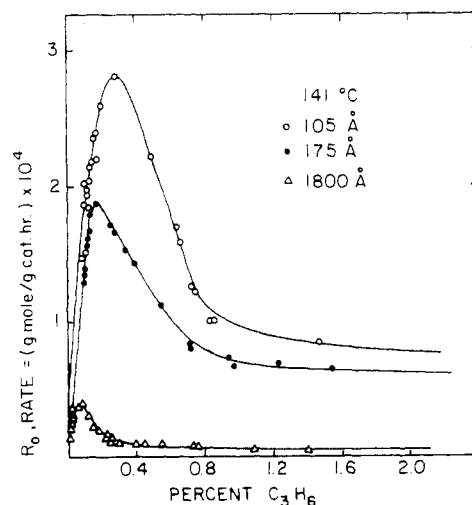

Figure 5. Global rate of propylene oxidation at three levels of sintering severity.<sup>20</sup>

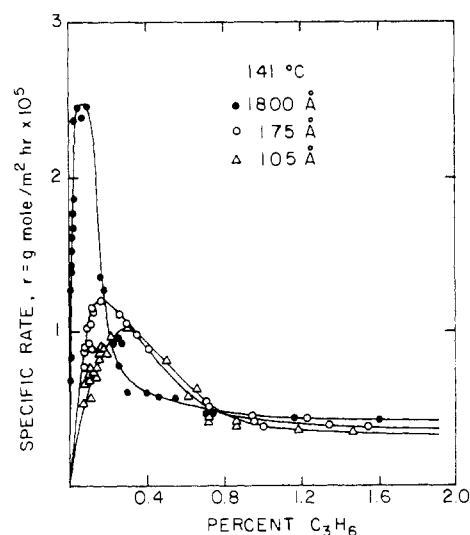

Figure 6. Specific rate of propylene oxidation at three levels of sintering severity.<sup>20</sup>

great over a CO pretreated Pt catalyst relative to the same catalyst sample pretreated in air ( $O_2$ ). These effects are reversible. Patently, we are dealing with two different catalysts: Pt and  $PtO_x$ .

### Olefin Oxidation

Subsequent studies of ethylene and then propylene total oxidation over supported Pt at diverse levels of sintering severity revealed (Figures 3–6): (1) Global kinetic behavior is qualitatively identical with that found in CO oxidation, i.e., normal and abnormal rate-olefin dependency (Figures 3 and 5); (2) Apparent conformity of these rate data to a kinetic model of the Langmuir-Hinshelwood form (eq 2) (Figure 4); (3) Specific rates (turnover numbers) suggestive of structure sensitivity (or sintering sensitivity) particularly in the region of normal kinetic behavior (Figure 6).

Note, however, Figures 3, 5, and 6: Both global and specific rates exhibit, with increasing olefin concentration, first order, then negative order (as eq 2 teaches), and at the higher concentrations, zero order. Equation 2 cannot predict zero order, only first and, in the limit, negative first order. Yet the rate data as shown in Figure 3 are apparently correlated by the linearized form of eq 2 (Figure 4).

Recall that it is common practice, in fashioning candidate rate equations, to assume one-step rate control. So for an  $n$ -step assumed sequence of elementary steps (a postulated mechanism),  $n$  possible rate expressions can be derived. Ideally, one contrasts the experimental rate data with each candidate model to find that model which best fits the data. In practice it is not unusual to discover that more than one model adequately describes observed behavior, models rooted in different rate-determining steps.

It may be justly asked: why should there be but one rate-determining step? Given the expectation that activation energies of the elementary steps need not be equal, why should a step slow at one temperature be the rate-determining step at another temperature? This issue, raised in the past,<sup>2</sup> has quite recently been invoked<sup>21</sup> as a promising basis for elucidation of oscillatory phenomena.

### Multistep Rate Control

This notion is appropriately illustrated in the instance of CO oxidation. Consider the sequence (also applicable to total oxidation of olefins over noble metals):

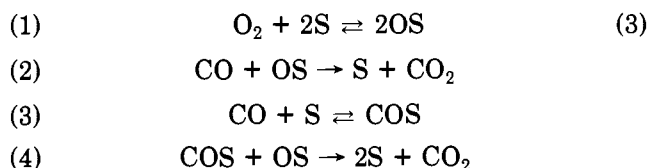

Steps 1 and 3 in eq 3 represent chemisorption upon catalytic sites, S; step 2 in eq 3 is the Eley-Rideal (E-R) reaction of a gaseous species (CO) with the chemisorbed coreactant while step 4 is the Langmuir-Hinshelwood (L-H) surface reaction event.

Following the conventional tactic, if, for example, step 2 in eq 3 is assumed to be rate determining, there results, in excess O<sub>2</sub>

$$R = k_2(\text{CO}) / (1 + K(\text{CO})) \quad (4)$$

Should step 4 in eq 3 be rate determining (in excess O<sub>2</sub>)

$$R = \frac{k_4(\text{CO})}{(1 + K(\text{CO}))^2} \quad (5)$$

In the light of the suggested sequence (eq 3) we have *parallel* sources of product (E-R and L-H) therefore for S<sub>0</sub> total sites

$$R = \frac{S_0^2 k_4(\text{CO})}{(1 + K(\text{CO}))^2} + \frac{S_0 k_2(\text{CO})}{(1 + K(\text{CO}))} \quad (6)$$

which exhibits first, negative, and zero orders with increasing  $K(\text{CO})$ , as observed<sup>13</sup> and, for propylene, the same behavior (Figures 3, 5, and 6). If we divide eq 6 by total sites S<sub>0</sub>, we find the specific rate or turnover number

$$\frac{R}{S_0} = \frac{S_0 k_4(\text{CO})}{(1 + K(\text{CO}))^2} + \frac{k_2(\text{CO})}{(1 + K(\text{CO}))} \quad (7)$$

or

$$\frac{R}{S_0} = S_0(\text{L-H}) + (\text{E-R})$$

(21) V. Halvacek and P. van Rampay, *Chem. Eng. Sci.*, **36**, 1587 (1981).

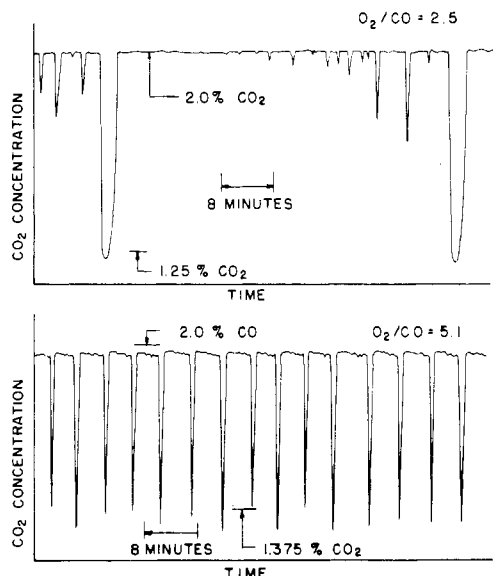

Figure 7. Observed oscillations in CO oxidation over supported Pt.<sup>33</sup>

so the L-H step is a function of S<sub>0</sub> and the E-R step independent of S<sub>0</sub> as observed<sup>13</sup> and noted in Figure 6 for propylene oxidation. The often observed weak dependency of  $K$  on temperature can also be rationalized.<sup>22</sup>

### Supported Metal Sintering

Man-made catalyst mortality compares rather unfavorably with nature's catalysts, e.g., enzymes, with respect not only to specificity but longevity. The decline of supported metal(s) activity can be ascribed to several phenomena: poisoning, coking, metal-support interaction, and sintering of the metal crystallites and/or support. Butt<sup>23</sup> has provided an exhaustive commentary on the general topic of catalyst deactivation. Here we dwell, albeit briefly, upon supported metal sintering. This phenomenon is, while temperature dependent, also known to be a function of ambient atmosphere. While sintering (crystallite growth) is a complex process, the global kinetics assume a simple power law form, where area,  $A$ , reduction with time  $t$  can be described by

$$-dA/dt = KA^n \quad (8)$$

The data set forth in Figure 2 may be roughly rationalized by  $n = 2$  for sintering in air. In other atmospheres, other global orders prevail.<sup>24</sup> As supported crystallites exist in a distributed form, global kinetic order is a result of "lumping" analogous to a lumped order of two for catalytic cracking of a hydrocarbon feed of diverse molecular weights. In a lumped system (a distribution of molecular weights or crystallite sizes) global phenomenological order will always be greater than the intrinsic order of individual events.

### Oscillatory Behavior

Sustained oscillations in metal-catalyzed oxidation have been observed in recent years, particularly in CO

(22) J. J. Carberry, *Nature (London), Phys. Sci.*, **189**, 391 (1961).

(23) J. B. Butt, *Adv. Chem. Ser.*, No. **109**, 259 (1972).

(24) J. Zahradnik, E. McCarthy, J. J. Carberry, and G. C. Kuczynski, *Mater. Sci. Res.* **10**, 199 (1976). See also: P. C. Flynn and S. Wanke, *Catal. Rev.—Sci. Eng.*, **12** 93 (1975).

oxidation over the noble metals, Pt<sup>13,25-29,33</sup> and more recently Pd and Ir.<sup>30</sup>

Diverse rationales have been invoked for these phenomena (a typical oscillation is shown in Figure 7). Of the theories suggested to data the most plausible is rooted in surface phenomena. Local activity variations at the microscopic level due to slow reversible oxidation-reduction of the surface and/or hot spots on the crystallites would seem to account, qualitatively, for a number of observations. As has been noted above, activity of a reduced Pt is found to be twice that observed upon an oxidized Pt. Thus a slow redox process can give rise to patches or "islands" of local activity and in consequence local hot spots—a thought sustained by recent IR thermograms observed by my colleague Schmitz and his students.<sup>32</sup>

Indeed a fine analysis of oscillations in CO oxidation over Pt has recently been revealed by Sales et al.<sup>30,31</sup> Magnificent accord between data and a theory rooted in slow oxidation-reduction of the Pt surface is found in that encouraging work. If, as Sales et al.<sup>31</sup> teach, a portion of the Pt surface is alternately oxidized to a low activity state and then reduced to a more active one, the CO "island" model may in fact be merely a consequence of the surface redox phenomenon. Furthermore, the surface redox model may be envisaged as that heretofore "5th step" in the Eigenberger<sup>34</sup> oscillatory model. In addition to chemisorption and reaction (steps 1 and 3 in eq 3, above) there is postulated a slow site consumption-regeneration step caused by an extraneous species X.



We need no longer invoke an extraneous agent as the sole cause of oscillations; rather, relatively slow reversible oxidation-reduction as the "5th step" to explain oscillations in CO oxidation as well as in olefin oxidation.<sup>35</sup> In the case of ethylene oxidation over Pt, Vayenas and his students, using polycrystalline Pt, directly measured periodic formation and decomposition of a surface Pt oxide during ethylene oxidation oscillations.<sup>35</sup>

Given then the experimental<sup>35</sup> and theoretical<sup>31</sup> evidence for slowly reversible surface oxide formation and other studies<sup>28,29</sup> pointing to the role of extraneous species in affecting oscillations, one might fairly envisage a slow surface redox process, itself affected by

(25) H. Beuch, P. Fieguth and E. Wicke, *Adv. Chem. Ser.*, No. 109, 615 (1972).

(26) J. P. Dauchot and J. Van Cakenberghe, *Oyo Butsuri, Suppl.*, 2, 533 (1974); *Nature (London), Phys. Sci.*, 246, 61 (1973).

(27) M. Sheintuch and R. A. Schmitz, *Catal. Rev.—Sci. Eng.*, 15, 107 (1977).

(28) M. B. Cutlip and C. N. Kenney, Proceedings of the 5th International Symposium on Chemical Reaction Engineering, Houston, TX; *ACS Symp. Ser.*, No. 65, 475 (1978).

(29) P. Varghese, J. J. Carberry, and E. Wolf, *J. Catal.*, 55, 76 (1978).

(30) J. E. Turner, B. C. Sales, and M. B. Maple, *Surf. Sci.*, 103, 54 (1981); 109, 591 (1981).

(31) B. C. Sales, J. E. Turner, and M. B. Maple, *Surf. Sci.*, 114, 381 (1982).

(32) G. A. D'Netto, J. R. Brown, and R. A. Schmitz, "Proceeding of 8th International Symposium on Chemical Reaction Engineering", Institute of Chemical Engineers Symposium Series No. 87, 1984, p 247.

(33) Ping-Chau Liao, Ph.D. Thesis, University of Notre Dame, 1981, *J. Catal.*, 74, 307 (1982).

(34) G. Eigenberger, *Chem. Eng. Sci.*, 33, 1263 (1978).

(35) C. G. Vayenas, C. Georgakakis, J. Michaels, and J. Tormo; *J. Catal.*, 67, 348 (1981).

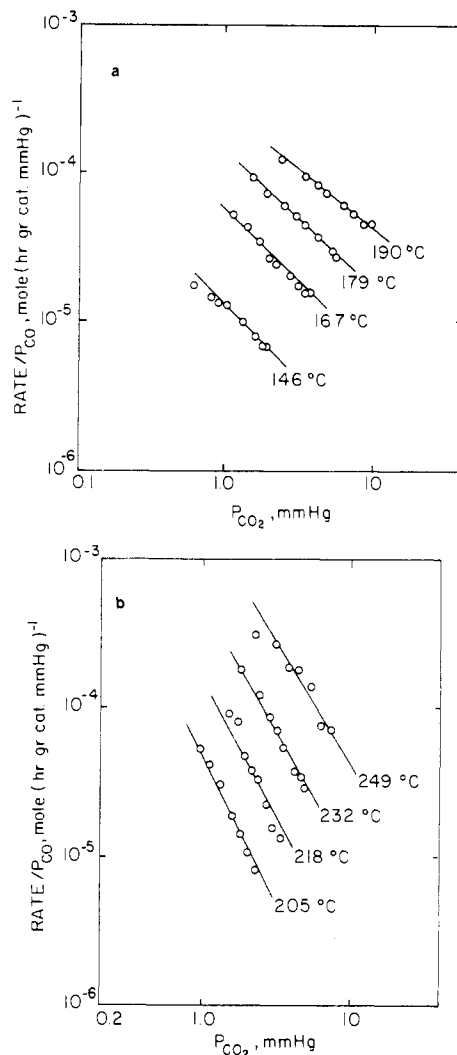

Figure 8. Kinetic correlation for CO oxidation over  $\alpha$ -Al<sub>2</sub>O<sub>3</sub> supported Ag-Au alloys (Ag + Au = 10%): (a) 9% Au; (b) 38% Au.

extraneous species and quite local "hot spots", as the general cause of these novel phenomena.

We terminate this brief comment on oscillations with the observation that reported oscillations in H<sub>2</sub> oxidation over Ni<sup>36</sup> may well be interpreted by a redox model with the additional invocation of a surface autocatalytic step, it being well-known that the H<sub>2</sub> reduction of NiO is autocatalytic due to H<sub>2</sub> chemisorption on and spillover from the reduced Ni surface. The same model would seem to apply to noble-metal-catalyzed oxidation of H<sub>2</sub>.

### Bimetallic Catalysis

Pioneering work by Sinfelt<sup>37</sup> which reveals the telling influence of bimetallic alloying or more properly clustering upon activity and selectivity in H<sub>2</sub>-hydrocarbon systems inspired us to explore the influence of supported metal alloying or clustering in oxidation catalysis. Confronted with the complexities (particularly severe activity-time fluctuations) in epoxidation of ethylene over supported silver, the effect of alloying silver was explored in CO oxidation.

(36) M. G. Slinko and M. M. Slinko, *Cat. Rev.—Sci. Eng.*, 17, 119 (1978).

(37) J. H. Sinfelt, J. L. Carter, and D. J. C. Yates, *J. Catal.*, 24, 283 (1972).

In Figure 8a,<sup>38</sup> there is shown an expected correlation of CO oxidation rate data for a supported Ag alloyed with up to 9 atomic % gold. The correlation conforms to previous findings for Ag

$$\text{rate} = k(\text{CO})/\text{CO}_2 \quad (10)$$

or more formally

$$\text{rate} = k'(\text{CO})/(1 + K(\text{CO}_2)) \quad (11)$$

suggesting that in excess O<sub>2</sub>, the rate-determining step is that of CO chemisorption upon a Ag surface unoccupied by adsorbed product CO<sub>2</sub> (a silver carbonate).

Note, however, in Figures 8b that with increasing gold content the order in inhibiting CO<sub>2</sub> increases. In the limit

$$\text{rate} = k(\text{CO})/(1 + K(\text{CO}_2))^2 \quad (12)$$

suggestive of a rate-determining step involving surface reaction between adsorbed O<sub>2</sub> and CO (Langmuir-Hinshelwood). Gold, per se, exhibits no activity in CO oxidation at temperature below 325 °C.

Given the inactivity of gold, the role of its alloying with active silver is patently that of changing the rate-determining step in CO oxidation by reason of (a) geometric spacing by Au of active Ag atoms and/or (b) electronic modification of Ag. Geometric and electronic effects are difficult to uncouple.

### Surface Enrichment

These data for Ag-Au alloys suggest an insensitivity of CO oxidation kinetics to Au content up to about 25% Au in Ag. We were thus prompted to address the issue of surface enrichment in bimetallic alloys—a phenomenon predicted by Gibbs yet defying quantitative analysis which would yield a model of enrichment consistent with the Gibbs adsorption theorem. A thermodynamically consistent model has been developed by colleague Kuczynski<sup>39</sup> which teaches that enrichment is governed, for a given alloy system, by the difference in surface tensions of the pure components. That difference is virtually zero for Ag-Au (thus no enrichment) *but* the difference is signal for Ag-Au in the presence of even small partial pressures of O<sub>2</sub>. Thus in our Ag-Au catalyzed oxidation of CO, the surface is largely enriched by Ag over a wide range (0–25%) of Au content.

This teaching<sup>39</sup> again sustains Sir High Taylor's insight of 1925:<sup>4</sup> the nature of the catalytic surface (i.e.,

enrichment in a bimetallic alloy) will be dictated by the reaction catalyzed. So in a reducing environment the Ag-Au alloy will not be enriched; i.e., surface and bulk compositions will be equal. *But* in an oxidizing atmosphere the surface of the Ag-Au alloy will be enriched by Ag due to the drastic reduction in the surface tension of Ag in the presence of O<sub>2</sub>.

### Conclusions

Surely the first conclusion we might fashion is that there remains much to be done. This, quite frankly, we hardly anticipated when in 1962 we selected Pt-catalyzed CO oxidation as a model catalytic reaction to evaluate the spinning basket catalytic reactor concept. That "simple" oxidation reaction was, then, incidental to the major objective. The spinning basket catalytic reactor is now a rather conventional reality. The "simple" test reaction has proved to be of awesome complexity, revealing as it does pathological kinetic behavior, apparent structure sensitivity, and oscillatory phenomena of evident diversity of form, frequency, and amplitude. That we are in a position to identify these complexities suggests the realization of some progress.

The general picture now offered by studies conducted in a number of laboratories throughout the world suggests that the focal point of future study is that seat of the heterogeneous catalytic event—the surface site, the chemical and physical nature of which is certainly determined, as Sir Hugh Taylor prophesized over a half century ago, by the reaction environment.

In consequence future inquiries must be devoted to in situ surface analyses, whereby the catalytic surface condition may be ascertained during the very process of catalysis.

If research opens new avenues, research in heterogeneous catalysis opens boulevards. As some sage put it quite aptly, research is a blind data with nature. Always a surprise, usually most pleasant in spite of frustrations.

*Over a period of years our efforts have been generously supported by the National Science Foundation and the donors of the Petroleum Research Fund, administered by the American Chemical Society. In the more recent era we've been grateful beneficiaries of unfettered support from the Amoco Oil and Chemical Co., the Mobil Oil Corp., the UOP Foundation, and Exxon Corp. I am particularly indebted to the Science and Engineering Research Council of the United Kingdom for support permitting me the opportunity to cooperate in the catalysis research programs at the Shell Department of Chemical Engineering, Cambridge University, U.K., and to Professor M. Boudart for the several opportunities to visit with his group at Stanford University.*

(38) C. Serrano, Ph.D. Thesis, University of Notre Dame, 1978. C. Serrano and J. J. Carberry, submitted for publication in *J. of Catal.*

(39) G. C. Kuczynski and J. J. Carberry, *Chem. Phys. Lett.*, 111 (No. 4 and 5), 445 (1984).